



“Q” PUMP INSTRUCTIONS

CeramPump®

I
S
O
9
0
0
1

SAFETY INSTRUCTIONS



Before using any Fluid Metering, Inc. product read the following safety instructions as well as specific product specifications and operating instructions.



Warning! Fire, electrical shock or explosion may occur if used near combustibles, explosive atmosphere, corrosive air, wet environment or submerged in fluid.

- Turn off the electrical power before checking pump for any problems.
- Connect motor, speed controllers, or any other electrical devices based on Fluid Metering Inc. specifications. Any unauthorized work performed on the product by the purchaser or by third parties can impair product functionality and thereby relieve Fluid Metering, Inc. of all warranty claims or liability for any misuse that will cause damage to product and/or injury to the individual.
- Power cables and leads should not be bent, pulled or inserted by excessive force. Otherwise there is a threat of electrical shock or fire.
- Replace any inline fuses only with fuse rating as specified by Fluid Metering, Inc.
- When pump/drive is under operation, never point discharge tubing into face or touch any rotating components of pump. In a power down thermal overload cut-in condition, unplug or turn off power to pump. Always allow a cool down period before restarting; otherwise, injury or damage may occur.
- For 30 seconds after power is removed from pump/drive: do not touch any output terminals. Electrical shock may occur because of residual voltage.



Caution! Fire, electrical shock, injury and damage may occur if not used in accordance with Fluid Metering, Inc. specifications and operation instructions.

- Do not put wet fingers into power outlet of unit.
- Do not operate with wet hands.
- Do not operate drive assemblies that require a hard mount (to be bolted down) unless they are mounted per Fluid Metering, Inc. specifications. If not, injury may occur and/or damage to unit.
- Do not touch any rotating pump or motor components: injury may occur.
- Do not run pump dry, unless designed for that service. Running dry is harmful to the pump, and will cause excessive heating due to internal friction.
- Check pump rotation and inlet/outlet pump port orientation before connecting power to pump. If not, injury may occur.
- When pulling out cords from outlets do not pull cord, grasp plug to prevent plug damage or electrical shock.
- Fluid Metering, Inc. Drive Motors become HOT and can cause a burn. **DO NOT TOUCH!**

INSTALLATION & OPERATING TIPS

1. CLEAN FLUIDS. Abrasives in the pumped fluid may damage cylinder and piston surfaces and should, therefore, be avoided. Carbon cylinder liners and stainless steel pistons are particularly susceptible to abrasion by particulate matter in the pumped stream. Ceramic piston/cylinder components are more tolerant of suspended solids, except solids that tend to flock and impede the movement of the piston in the cylinder.

2. COMPATIBLE FLUIDS. Pump only fluids compatible with materials of construction of the pump head you have selected.

3. WET OPERATION. The pumped fluid provides surface cooling and lubrication to the piston and cylinder of your FMI PUMP. Therefore, avoid dry operation (except pumps specifically designated “gas pump”).

4. FLOW VOLUME AND DIRECTION. Angular deflection of the cylinder with respect to the zero point on the calibration scale of your FMI “Q” PUMP controls flow magnitude and direction e.g., with the cylinder pointer at 10 on the left scale, fluid will be passed from the right port to the left port at 100% of the maximum rated volume; with the pointer at 10 on the right scale, fluid will pass from the left port to the right port at maximum rate. Set at 5 on the scale, flow rate will be 50% of maximum; at 4, it will be 40%; at 3, 30%, etc., etc. The

flow control setting may be changed (including flow reversal) at any time while the pump is operating or idle. Slightly loosen the two thumb screws and turn the STROKE LENGTH ADJUSTMENT KNOB. Retighten thumb screws once the desired setting is reached.

5. PISTON SEALS. The R408 seals that keep your PUMP piston dry are not “just ordinary plastic discs.” They are precisely cut and hot formed from sheets of a chemically inert fluorocarbon, specifically formulated for resistance to wear, abrasion, heat and chemical attack.

Each R408 seal possesses an exceptional mechanical memory which allows it to maintain a relatively constant wiping pressure on the piston, compensating for seal wear as it occurs. Properly maintained in clean condition, the original seals on a FMI PUMP may be expected to last the life of the pump. If they are removed for any reason, they should be carefully cleansed of all foreign particles prior to re-assembly. Seal seats must also be free of particles. (please see para 18)

6. DIAL INDICATOR. (optional) The Dial Indicator Kit is for fine adjustment and continuous monitoring of your “Q” pump flow rate settings.

To adjust Dial Indicator equipped pumps:

1. Loosen thumb screws, turn STROKE LENGTH ADJUSTMENT KNOB, moving cylinder assembly to neutral (zero-flow position).

2. Adjust indicator pointers until they read zero on

both dials.

3. You are now ready for fine setting by turning STROKE LENGTH ADJUSTMENT KNOB until you achieve desired flow rate on dial. To prevent system backlash always turn STROKE LENGTH ADJUSTMENT KNOB two turns or one full revolution of large dial beyond desired setting, then adjust back.

7. 4-20 mA CONTROL for automatic response to remotely generated 4-20 milliamp signals is standard on V300 controllers. The input can be either grounded or ungrounded. The current source connects to terminal posts mounted on front cover assembly of the STROKE RATE CONTROLLER. Be sure to observe correct polarity. For complete hook-up and operating information see page 10.

8. PRESSURE. Do not operate pump against head pressures in excess of design specification. Drive arm on piston may bend or break under overload and other irreparable damage may be suffered. **Check your fluid circuit before applying power to the pump!**

9. ELECTRICAL PROTECTION. All FMI PUMPS are positive displacement in instruments and should be protected by lowest possible “slo blow” fuse or circuit breaker electrical arrangements. “QV” units come equipped with .75 amp fuses.

10. NOISE AT HIGH PUMP RATES. A metallic hammering noise during operation of your pump

(particularly high speed units such as QB, QD, QDX, and QV) when pumping liquids indicates presence of gas bubbles in the pumping chamber which are reducing pumping capacity and may be damaging cylinder walls. Such bubbles may be traced to 1) a poor seal at the suction fitting, 2) fluid vaporization (cavitation) or, 3) degassing of the fluid.

a) To correct suction fitting leaks in stainless steel pump heads, remove fitting and wrap two layers of Teflon tape (standard Lab plumbing variety, 1 to 2 mil thick x 1/2" wide) tightly into the threads of the fitting. Replace fitting in cylinder port, drawing threads tightly on the Teflon tape. (see para 16).

b) To eliminate vaporization and degassing noise, reduce suction load. This may be accomplished by: 1) Using the 3/8" dia. TUBE ADAPTER R412-2 supplied with each pump on the suction line of the pump head to increase inside diameter of the suction line (use 1/2" dia. TUBE ADAPTER R412-6K on -3 PHM's.); 2) reduction of suction lift height; 3) pressurization of the suction supply container; 4) locating pump below supply source to permit gravity flow aid; 5) reduce viscosity of fluid by heating or thinning; 6) reduce flow rate by adjusting pump to lower setting on flow scale; 7) install FMI PD-HF PULSE SUPPRESSORS in suction and discharge lines.

Improvements in noise abatement and pump life can be gained by putting pulse suppression hardware in the plumbing circuits adjacent to the pump suction and discharge ports - particularly with high speed pumps that are plumbed with rigid tubing. Theory holds that if part of a generated pulse is resiliently stored, the part not stored is smaller and thus easier to get into motion; the stored part of the pulse dissipating behind the part that is in motion sustains motion, causing an undulating flow to be transmitted rather than a series of pulses. Result: less noise, less energy used and less agitation of the pumped fluid. So for pulse noise and vibration problems, put a little resilience in your circuit. There are a number of rather easy ways to do it:

c) The simplest method is to use resilient tubing between the pump and the fluid circuit. Experiment a bit with standard elastomers - viton, hypalon, gum rubber, soft vinyl or other. Use only unreinforced tubing (reinforcement takes away the resilience). Always shield this type of arrangement so that a possible tube rupture will not endanger people or equipment.

d) Another popular pulse suppression arrangement involves a gas bubble trap as described in the final sentences of para. 12. A bubble in such a vertical trap will suppress pulse shock and noise temporarily. However, since gas and a liquid in contact under agitated conditions seldom stabilize, the trapped gas may absorb into the passing liquid and disappear leaving no pulse suppression or the fluid may contribute to the gas quantity, overload the trap and cause random pumping errors as occasional bubbles enter the flow stream. This can be overcome by fitting a soft slug of closed-cell plastic foam or a soft pillow of thin-wall plastic tubing (ends sealed) into the vertical dead end extension of the fluid line. The gas trapped in the foam or pillow will provide the required resilience but will not be absorbed by the flow stream.

e) Since each fluid and circuit exhibits differing characteristics, a bit of experimentation may be

necessary. The results are usually worth the effort.

11. FOR BEST LOW FLOW PUMPING RESULTS:

Use a pump having a maximum flow rating as near to the desired flow rate as possible and keep suction and discharge pressures essentially constant (see para 13). FMI pumps using R479 Low Flow Kits or designated LF are specifically designed for low flow/low dead volume, 1/4-28 flat bottom fittings.

12. LOW FLOW BUBBLE PROBLEMS.

A common cause of trouble in metering pump applications requiring low flow rates - a few milliliters per minute or less - is the seemingly inevitable gas bubble trapped in the pumping head of the metering pump. It expands on the suction stroke and contracts on the discharge stroke, allowing little, if any, liquid to pass through the pump. Such bubbles, though often attributed to leaks in pump seals, can usually be traced to gases released by the pumped fluid in response to pumping agitation or pressure/temperature changes. When so identified, this potential source of metering pump error can be effectively controlled in most fluid circuits.

The familiar bubbles that form on the inside walls of a tumbler of tap water after it stands for a period of time at room temperature demonstrate the typical liquid degassing that results from pressure reduction (water line pressure to atmospheric) and/or temperature elevation (from ground ambient to air ambient). In this case, the bubbles contain air, hydrogen, carbon dioxide or other gaseous materials carried in the water; only small quantities of vaporized water are present. Some liquids respond to agitation and/or pressure/temperature changes by chemically separating into liquid and gas fractions; others simply vaporize, physically changing from liquid to gaseous form. Examples of liquids releasing gas or changing from liquid to gaseous form in response to agitation and temperature/pressure changes are numerous in the modern technical environment and many techniques have been devised to compensate for or correct their presence. The most common practices for bubble control employ:

a) pressure on the suction side of the pump circuit to encourage gas retention in the liquid or,

b) employ natural buoyancy of the bubbles to carry them away from or through the pump head.

To apply pressure on the suction side of the pump, locate the pump physically below the supply vessel. Each two feet of elevation difference represents pressure of approximately one pound per square inch (psi). Bubbles that do occur will return to the supply vessel by buoyant lift. This is called a positive suction or flooded suction arrangement. If it is necessary to draw liquid up from the supply vessel to the pump head, negative suction pressure must be contemplated - again, approximately 1 psi per two feet of lift. Most liquids will release some gas when held at negative pressure and since the volume of gas released is generally proportionate to the volume of liquid subjected to the negative pressure, suction line diameter should be kept small for small flows (except heavy, viscous or tacky liquids which require large flow area for mobility). A vertical dead-end extension of the suction line can be provided above the pump suction port to trap line-generated bubbles before they enter the pump. This extension should be liquid filled at

the start of a pumping period. Stand the pump vertically by loosening the screws and repositioning the Multi-Position Tilt Stand Q650 so that pump is in standing position, or hang the pump vertically by its base key slots. The discharge port should now be above the suction port allowing bubbles that enter the pump head to pass directly through with buoyant assist. Discharge lines should be inclined upward from pump head and bubble traps should be purged as often as necessary to assure liquid flow continuity.

13. SYSTEM ACCURACY FACTORS.

Several interrelated factors are involved in the exceptional operating accuracy possible in systems using FMI PUMPS. Of primary concern are the following:

a) FMI PUMP DISPLACEMENT precision is based on a simplified positive stroke mechanism which has no secondary linkages to produce stroke to stroke mechanical errors and has no gravity actuated or spring loaded valves to introduce random valve seating errors. The single mechanical linkage component between the PUMP piston and its drive elements is a precision spherical bearing which transforms circular drive motion into elliptical thrust motion (reciprocation). The total mechanical clearance of this linkage is less than 0.1% of the maximum pump stroke length or, approximately 0.0003". Thus it may be said that PUMP displacement precision (stroke to stroke) is in the order of the mechanical linkage clearance; that is to say, stroke to stroke displacement is reproducible to less than 0.5% within the rated capacity of a given pump model.

b) FMI PUMP VALVING is performed by a flat in the piston which is mechanically aligned with one cylinder port during the suction portion of each stroke and with the other cylinder port during the discharge portion of each stroke. The flat alignment is controlled by the single drive bearing discussed in the preceding sentences. The valve action is therefore mechanically precise, and free of random closure variations.

c) FLUID SLIP, a term commonly used to describe the migration of fluid around the internal moving parts of gear, lobe and vane pumps, is the volumetric difference between physical component displacement and fluid through-put of a pump system. In the FMI PUMP, slip loss refers to the fluid which passes through the clearance space (approx. .0002") between the piston and the cylinder wall. Since this clearance represents a restrictive passage of essentially constant dimension, it will be readily seen that the slip rate is determined by viscosity, pressure and time: e.g. assuming constant fluid viscosity and pressure, slip will be a smaller factor in a high repetition rate pump (short time per stroke) than in a low repetition rate pump. As viscosity increases and pressure decreases, time (or repetition rate) becomes less a significant contributor to slip loss.

d) STROKE REPETITION RATE is directly related to drive motor speed which in turn is influenced by work load and electrical supply voltage, i.e., motor speed decreases when work load increases and when electrical supply voltage (115 Volts AC) decreases. This motor speed variation may amount to as much as 15% for work load variations between zero discharge pressure and maximum rated discharge pressure. A 10% voltage drop may

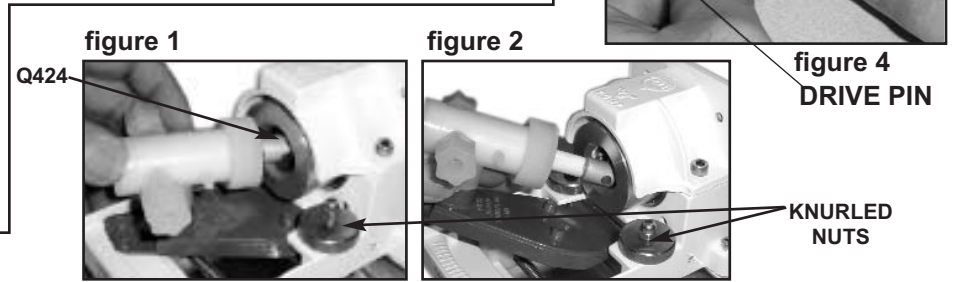
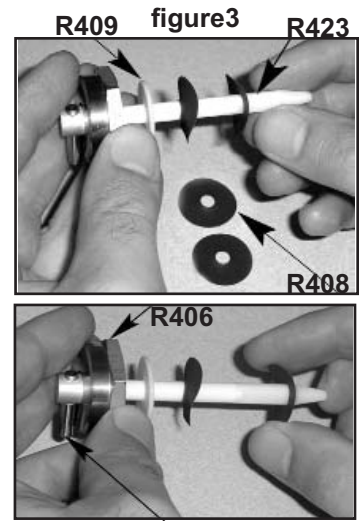
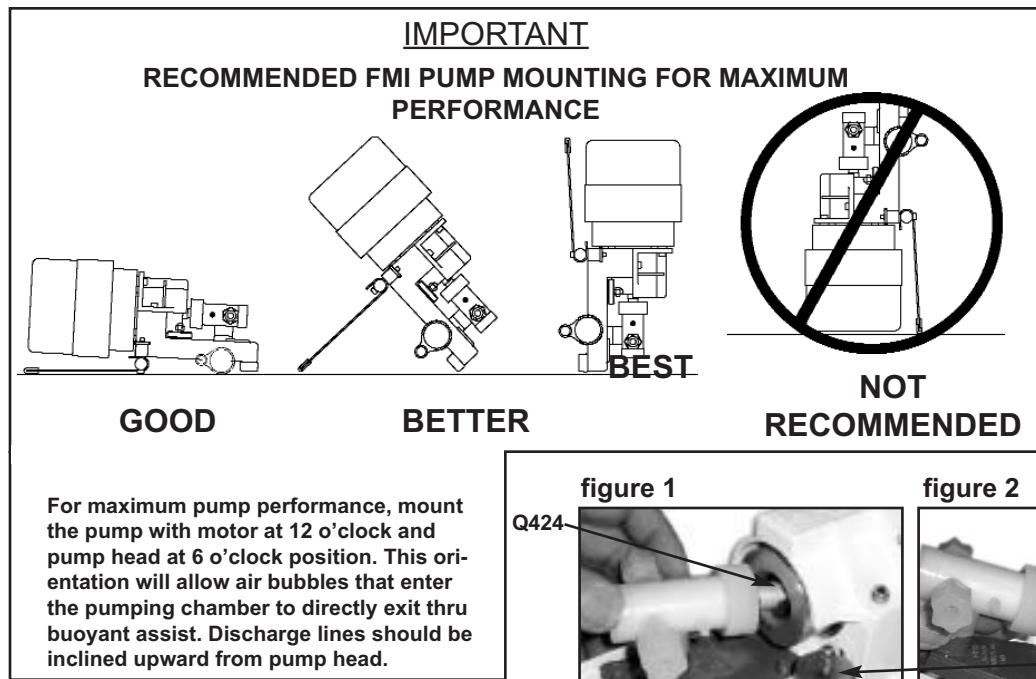

result in as much as 20% motor speed reduction when the pump is operating against a significant head pressure.

e) THE FLOW STABILITY (precision) of an FMI PUMP is therefore principally related to consistency in fluid slip rate and stroke repetition rate and these functions in turn are related to external system load factors such as viscosity, differential pressure and electric line voltage; i.e., when load factors remain essentially constant, slip rate and repetition rate remain essentially constant; when viscosity increases, fluid slip rate and stroke repetition rate both decrease; when differential pressure increases fluid slip rate increases and stroke repetition rate decreases. In short, FMI PUMP PRECISION is influenced by fluctuations of fluid differential pressures, fluid viscosity and electric line voltage. When these factors are controlled predictably reproducible pumping precision better than 0.5% may be expected.

MAINTENANCE & REPAIR INSTRUCTIONS

14. LUBRICATION. Pump drive elements are provided with oil fittings at all appropriate points. Use high grade machine oil at regular intervals. A dab of good grease on PISTON DRIVE PIN just before it is inserted into the RADIAL BEARING in the SPINDLE ASSEMBLY does a world of good for the bearing and pin.

15. CHANGING THE LIQUID END OF YOUR FMI "Q" PUMP. (figures 1,2).

- a) To remove "Q" Pump Head Module (QPHM):
 1. Turn power off.
 2. Rotate STROKE LENGTH ADJUSTMENT KNOB to position PUMP HEAD CARRIER Q410-2 all the way to the extreme right or left of scale (fig. 1).
 3. Rotate SPINDLE ASSEMBLY Q424 to place PISTON DRIVE PIN at 3 or 9 o'clock position (facing cylinder head).
 4. Loosen two KNURLED NUTS.
 5. Lift QPHM and draw gently away from Q424 SPINDLE ASSEMBLY (fig. 2).

6. Move QPHM up and to the left while slipping DRIVE PIN out of RADIAL BEARING.

b) To replace QPHM:

- 1. With PISTON ASSEMBLY R423 extending approximately 1-1/4" from CYLINDER NUT R406K and DRIVE PIN in the 3 or 9 o'clock position, insert PIN into the RADIAL BEARING in the SPINDLE ASSEMBLY.
- 2. Slide QPHM into position on BASE making sure locator on bottom of CARRIER Q410-2 drops into slotted portion of FOLLOWER Q454-2 on base.
- 3. Tighten KNURLED NUTS on Q616 assembly

16. CHANGING FITTINGS ON STAINLESS STEEL PUMP HEADS

IMPORTANT!

Fittings screwed too tightly into stainless steel pump heads will contact port seals and may cause piston/cylinder damage. Use extra layers of Teflon tape on threads when necessary to avoid such excessive penetration.

17. CLEANING PUMP HEAD. Routine flushing with solvent before shut-down will suffice for most applications - set pump for maximum stroke and operate until solvent appears clear at discharge port. If periodic teardown for detail cleaning is required, remove parts with care to avoid damage to piston, cylinder and gland. Wipe all parts with lintless oil saturated cloth. Operate by hand after reassembly to assure free movement of parts prior to application of power.

17.1 CAUTION! Ceramic piston/cylinder sets are particularly sensitive to neglect and may "freeze" if allowed to dry out without adequate cleansing.

Some users actually remove the piston from the cylinder after solvent cleaning and store the component parts in disassembled condition until the pump is again required. Others fill a loop of flexible tubing with fluid that will thin or neutralize the last fluid pumped. They then connect one end of the tube to the pump suction port, the other to the discharge port. With this loop positioned above the pump head, the ceramic surfaces and seal areas will stay moist and mobile for extended idle peri-

ods. If, however, a piston (ceramic or stainless steel) does freeze in the cylinder, **DO NOT TRY TO FORCE IT FREE!** Be gentle. Try to remove the pump head (refer para 15) from the base assembly so that the whole assembly can be soaked in a suitable solvent. If the head is not conveniently removable, the tube loop discussed in the prior paragraph may permit solvent to dissolve the "frozen" residue in reasonable time. Having a spare pump head on hand in case of emergency is always a good idea.

17.2 SANITARY SERVICE. FMI sanitary pump heads, designated SAN are designed to conform with the cleansing standards of the U.S. Food and Drug Administration.

To clean individual component parts:
 a) Unscrew 2 CYLINDER NUTS R406-S and 2 PORT NUTS 110348-P.

- b) Remove piston and seal components released by step a) above;
- c) Use fingers to wiggle LINER R407-C slipping it from CYLINDER CASE R405-SAN;
- d) Cleanse and sterilize component parts as per government regulations for parts manufactured of Alumina Ceramic, Type 316 Stainless Steel and Teflon. After cleaning, reassemble the components as follows:
- e) Assemble piston/seal components as per instructions para 18 a,b,c;
- f) Orient CYLINDER LINER R407-C in CYLINDER CASE R405-SAN in such a manner that the side port flats on CYLINDER LINER R407-C should be visible through the side port openings on CYLINDER CASE R405-SAN.
- g) Place one each port seal component R412-T into each side port of CYLINDER CASE R405-SAN using finger pressure across the two ports to assure flush seating of the seal surfaces on the cylinder liner flats.
- h) Apply PORT NUT 110348-P to each port, finger tight.
- i) Carefully insert piston into cylinder liner until threads of CYLINDER NUT R406-S meet threads of CYLINDER CASE R405-SAN. Tighten NUT R406-S finger tight.

Continued on Page 12

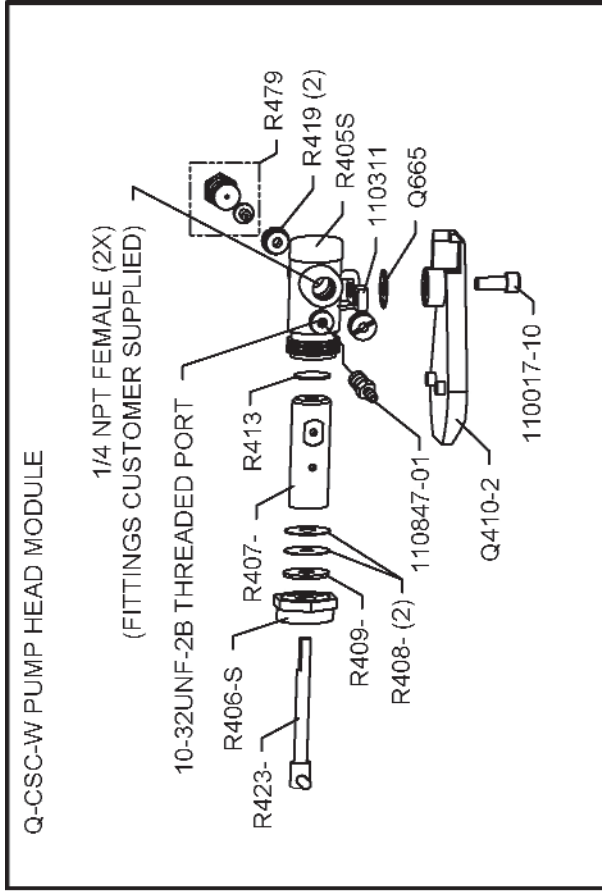
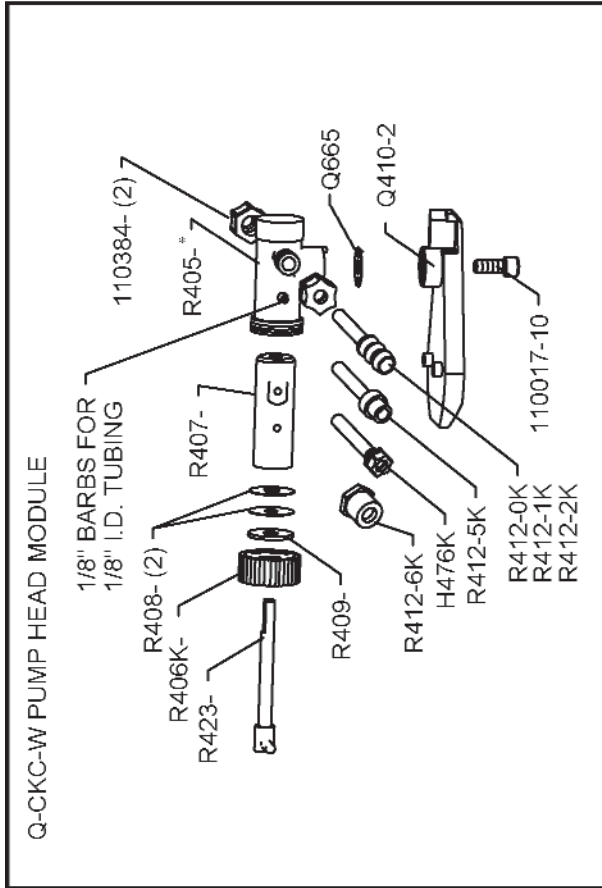

CERAMIC PISTONS AND CYLINDER LINERS SOLD AS SETS ONLY

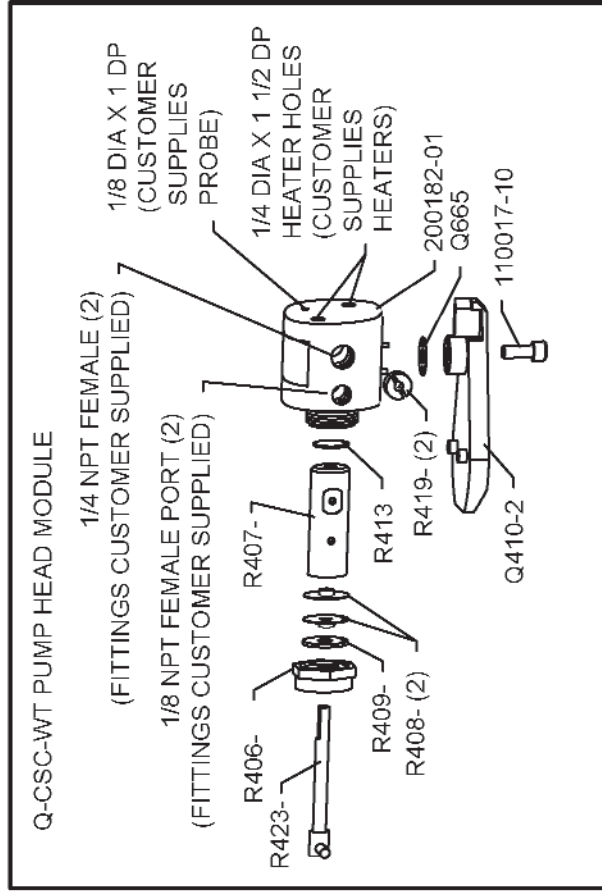
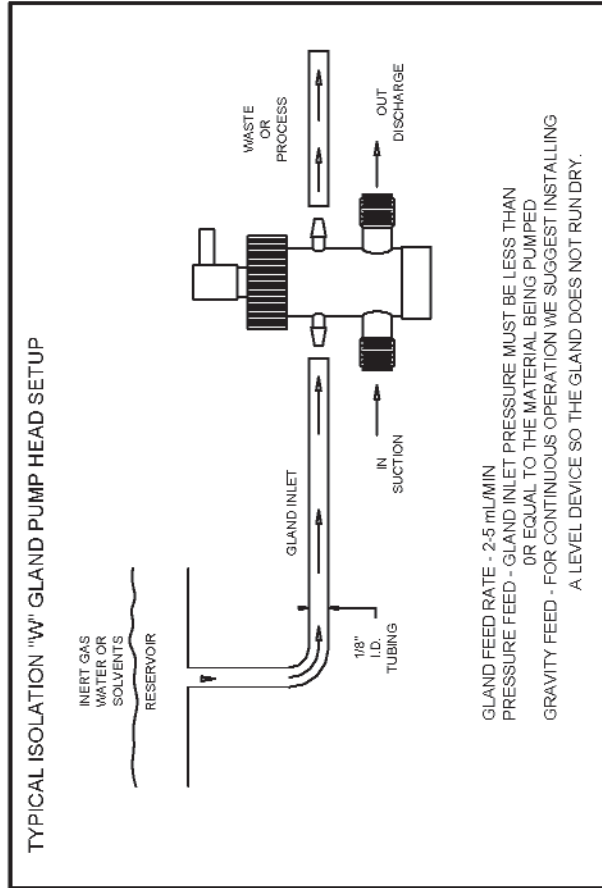

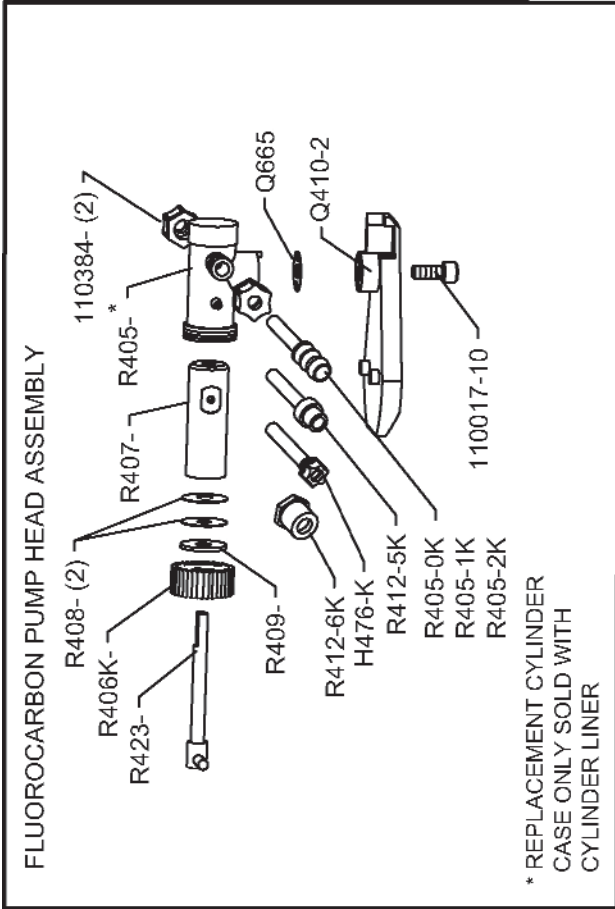

IMPORTANT!

WHEN ORDERING REPLACEMENT PARTS PLEASE MENTION MODEL AND SERIAL NUMBERS OF THE PUMP ON WHICH THEY WILL BE USED.

REPLACEMENT CYLINDER CASE (R405-K) ONLY SOLD WITH CYLINDER LINER

CERAMIC PISTONS & CYLINDER LINERS SOLD AS SETS ONLY

PLEASE NOTE: FMI WILL PROVIDE A REPAIR ESTIMATE WITHIN 48 HOURS (SEE PAGE 7 FOR DETAILS)

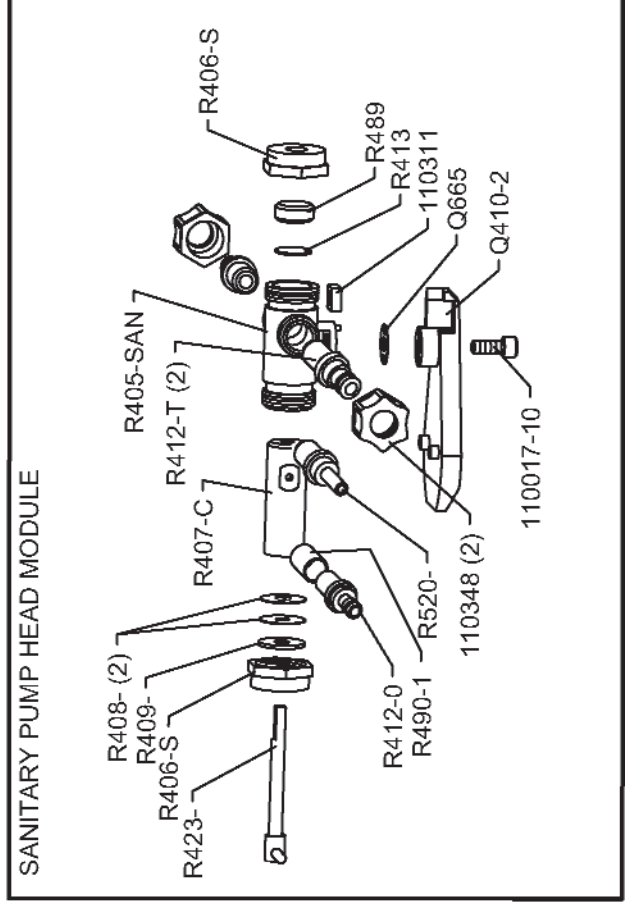
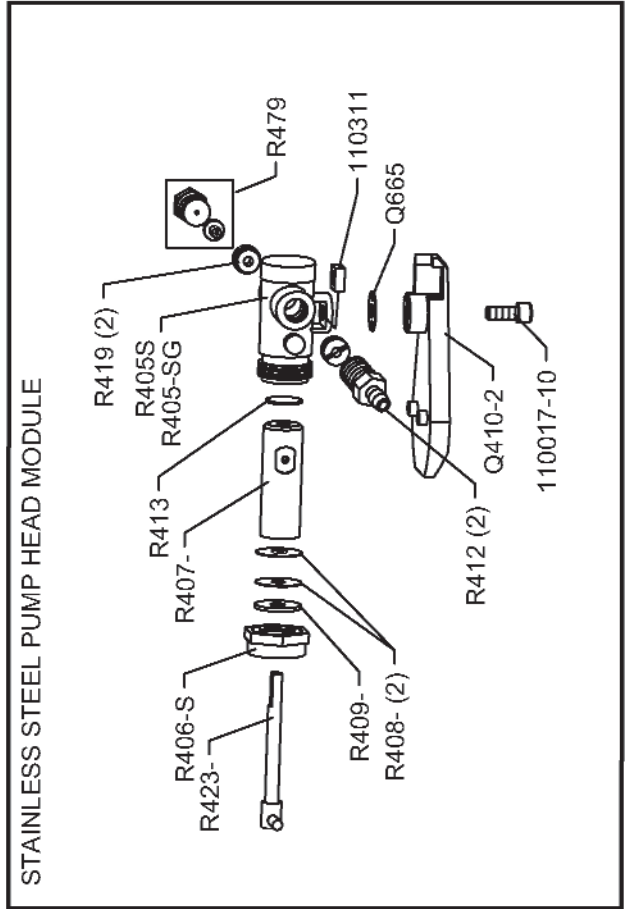

CERAMIC PISTONS AND CYLINDER LINERS SOLD AS SETS ONLY

PUMP HEAD INFORMATION

THINGS YOU SHOULD KNOW BEFORE ORDERING THE FLUID HANDLING PORTION (or parts thereof) OF AN FMI MODEL Q PUMP, i.e. the removable assembly that is often referred to as the liquid end, the piston/cylinder set, or the Pump Head Module (PHM) assembly.

To accommodate the diverse demands of laboratory and industrial pumping applications, FMI's Q-Pumps are arranged to accept interchangeable PHM's with differing chemical and mechanical characteristics. There are a number of these assemblies from which the pump user may select in solving difficult fluid pumping problems.

To simplify the selection process, each individual type of fluid handling assembly (piston/cylinder set) is designated by an alpha-numeric code which permits direct identification of pertinent factors.

Q-PUMP DESIGNATIONS

Example:

Q-1-SAN denotes a sanitary construction pump head assembly having a 1/4" diameter ceramic piston, ceramic cylinder liner and a 316 stainless steel cylinder case.

PLEASE NOTE:

1. When the last three of the above shown categories are not called out, standard materials and construction are implied (CKC).
2. If SAN is designated in the last category, the preceding three categories will be designated CSC as required by FDA specifications.
3. Piston seals made of an inert material, Rulon AR, are used in all FMI type Q Pump Heads except

high speed pumps fitted with stainless steel pistons (these use Rulon J seals) and sanitary (SAN) pump heads which require virgin Teflon (T) seals. Specify AR, J or T after the pump head code designation to order pump heads assembled with other than standard seals.

4. Ceramic cylinder liners should be used with ceramic piston only.

Pump Head Materials Configuration

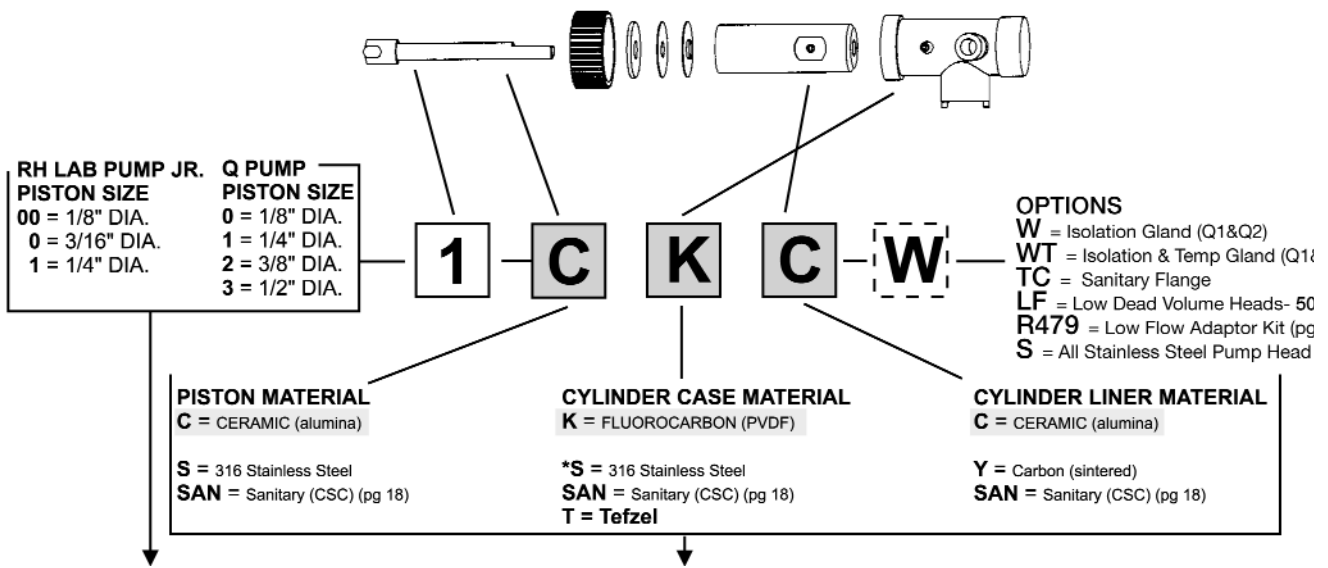

PUMP HEAD MODULE CODES									
PISTON SIZE CODE	MATERIALS OF CONSTRUCTION								
	CKC	CKY	CSC	CSY	SAN	SKY	SSY	STY	CTC
Q0									
Q1									
Q2									
Q3									
WETTED PARTS	CERAMIC PVDF	CERAMIC PVDF CARBON	CERAMIC 316 SS	CERAMIC 316 SS CARBON	CERAMIC TEFLON	316 SS PVDF CARBON	316 SS CARBON	316 SS TEFLON CARBON	CERAMIC TEFLON
MAX.TEMP	212 F	212 F	350 F	350 F	350 F	140 F	140 F	140 F	212 F
OPTIONS (add Option Code & cost to Pump Module for complete price and part number)									
LF	CF	CF	CF	CF	CF	CF		CF	CF
W									
WT									
TC									
R479									
S("Q" Only)									

See Materials of Construction section in the Fluid Metering catalog for more information on wetted parts *316 Stainless Steel cylinder cases accept 1/4 NPT male fittings.

When ordering specify: Piston Size Code + Material of Construction + Option Code (Q1+CKC+W = Q1CKC-W

*CF = Consult factory for details

Q PUMP HEAD MODULE - PARTS PRICE LIST

PART NO.	DESCRIPTION	PART NO.	DESCRIPTION
Q410-2	CARRIER	R412-1	ADAPTER, S.S. 1/4 NPT TO 1/4" I.D. TUBE
Q410-3	CARRIER STAINLESS STEEL	R412-2	ADAPTER, S.S. 1/4 NPT TO 3/8" I.D. TUBE
Q665	SPACER	R412-0K	ADAPTER, FLUOROCARBON 1/8" I.D. TUBE
R405-S	CYL CASE, STAINLESS STEEL	R412-1K	ADAPTER, FLUOROCARBON 1/4" I.D. TUBE
R405-1S	CYL CASE, SS, TEMP GLAND	R412-2K	ADAPTER, FLUOROCARBON 3/8" I.D. TUBE
R405-SAN	CYL CASE, SANITARY STAINLESS STEEL	R412-5K	ADAPTER, FLUOROCARBON 1/4-28 THD
R405-SG	CYL CASE, SS ISOLATION GLAND	R412-6K	ADAPTER, FLUOROCARBON 1/2" I.D. TUBE
R406-K	GLAND NUT, FLUOROCARBON	R412-07	ADAPTER, S.S. 1/4" I.D. TUBE, SAN
R406-0K	GLAND NUT, FLUOROCARBON 1/8" PISTON	R412-08	ADAPTER, S.S. 3/8" I.D. TUBE, SAN
R406-1K	GLAND NUT, FLUOROCARBON 1/4" PISTON	R412-1T	ADAPTER, TEFLON 1/4" I.D. TUBE, SAN
R406-2K	GLAND NUT, FLUOROCARBON 3/8" PISTON	R412-2T	ADAPTER, TEFLON 3/8" I.D. TUBE, SAN
R406-3K	GLAND NUT FLUOROCARBON	R413	CYLINDER HEAD SEAL
R406-S	CYLINDER NUT R405-S, R405-SAN	R413-1	CYLINDER HEAD SEAL, R405-1K
R407-0	CYLINDER LINER	R419	CYLINDER PORT SEAL, R405-S
R407-1	CYLINDER LINER	R423-1C*	PISTON
R407-2	CYLINDER LINER	R423-2C*	PISTON
R407-1C*	CYLINDER LINER	R423-3C*	PISTON
R407-2C*	CYLINDER LINER	R423-0S	PISTON
R407-3C*	CYLINDER LINER	R423-1S	PISTON
R408-1A	LIP SEAL, RULON AR 1/4"	R423-2S	PISTON
R408-2A	LIP SEAL, RULON AR 3/8"	R479	LOW FLOW KIT (FITS R405-S)
R408-0J	LIP SEAL, RULON J 1/8"	R489	SPACER, SANITARY CYLINDER GROUP
R408-1J	LIP SEAL, RULON J 1/4"	R490-1	PORT SLEEVE, SANITARY CYLINDER GROUP
R408-2J	LIP SEAL, RULON J 3/8"	R520-1T	ADAPTER, TEFLON 1/4" O.D. STRAIGHT, SAN
R408-1T	LIP SEAL, TEFLON 1/4"	R520-2T	ADAPTER, TEFLON 3/8" O.D. STRAIGHT, SAN
R408-2T	LIP SEAL, TEFLON 3/8"	H476-K	SML TUBE ADAPTER SET, 1/8" O.D. (OPTL)
R408-3A	LIP SEAL, RULON AR 1/2"	110017-10	SCREW, SKT HD CAP 1/4-20 X 5/8"
R408-3T	LIP SEAL, TEFLON 1/2"	110311	NUT, SQUARE 1/4-20
R409-0	GLAND WASHER, TEFLON 1/8"	110348-P	SAN PORT NUT, PLASTIC
R409-1	GLAND WASHER, TEFLON 1/4"	110348-S	SAN PORT NUT, STAINLESS STEEL
R409-2	GLAND WASHER, TEFLON 3/8"	110384-K	FERRULE NUT 1/4, KYNAR
R409-3	GLAND WASHER TEFLON 1/2"	110384-T	FERRULE NUT 1/4", TFE
		110847-01	BARBED FITTING 10-32 UNC-2B 1/8" ID TUBING
		200182-01	CYL CASE, SS HIGH TEMP GLAND
		500074	LIP SEAL INSTALLATION TOOL, 1/8"
		500071	LIP SEAL INSTALLATION TOOL, 1/4"
		500080	LIP SEAL INSTALLATION TOOL, 3/8"
		500081	LIP SEAL INSTALLATION TOOL, 1/2"

* CERAMIC PISTONS & CYLINDER LINERS SOLD AS SETS ONLY

*Please
call for Pricing*

*Please
call for Pricing*

PUMP HEAD REPAIR SERVICE

Should your FMI PUMP or PUMP SUBASSEMBLY need repairs, you should first contact the Customer Service Department for a **SERVICE SAFETY ASSURANCE FORM** and a **RETURN AUTHORIZATION NUMBER**, you may then ship it to us post-paid. You will be charged a flat service fee for each Pump Head Module returned plus the cost of parts used and the postage required to return it to you. The Pump Head Module service fee includes inspection, clean and test to agreed specifications and the replacement of Lip Seals and Gland Washer. After examining a returned pump or subassembly by FMI Service Department, you will be requested to approve the charges before repair work is started.

PARTS ORDERS

MINIMUM ORDER APPLIES FOR DOMESTIC or FOREIGN (Invoice price exclusive of shipping)

SHIPPING

Parts and repair orders will be shipped via United Parcel Service or U.S. Postal Service unless other means are specified.

ALL PRICES ARE QUOTED IN U.S. DOLLARS, FOB SYOSSET, NY - Subject to change without notice.

For Additional Information Call - Toll Free 800-223-3388 or email us at: pumps@fmipump.com

FMI MODEL Q PUMPS PARTS IDENTIFICATION SHEET Q431-05

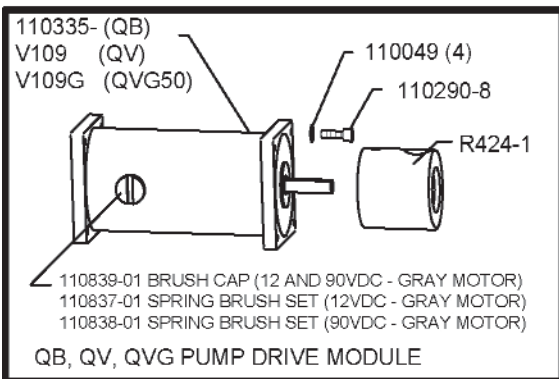
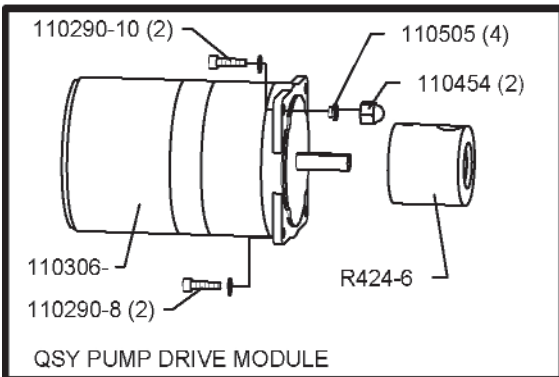
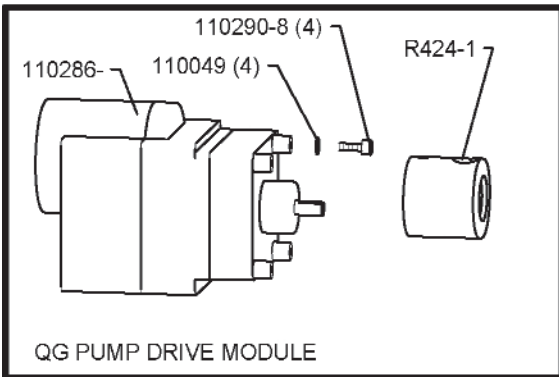
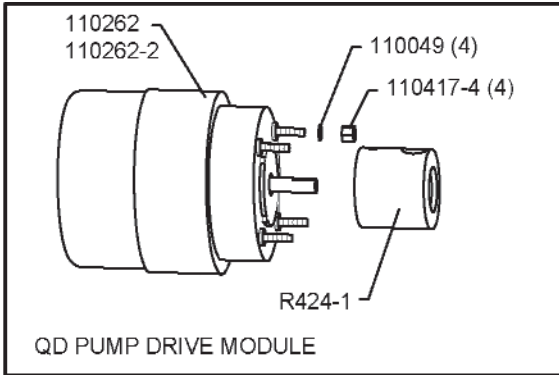

Q421-3 BASE ASS'Y, QB, QD, QV
Q421-4 BASE ASS'Y, QSY
Q421-6 BASE ASS'Y QG, QVG50

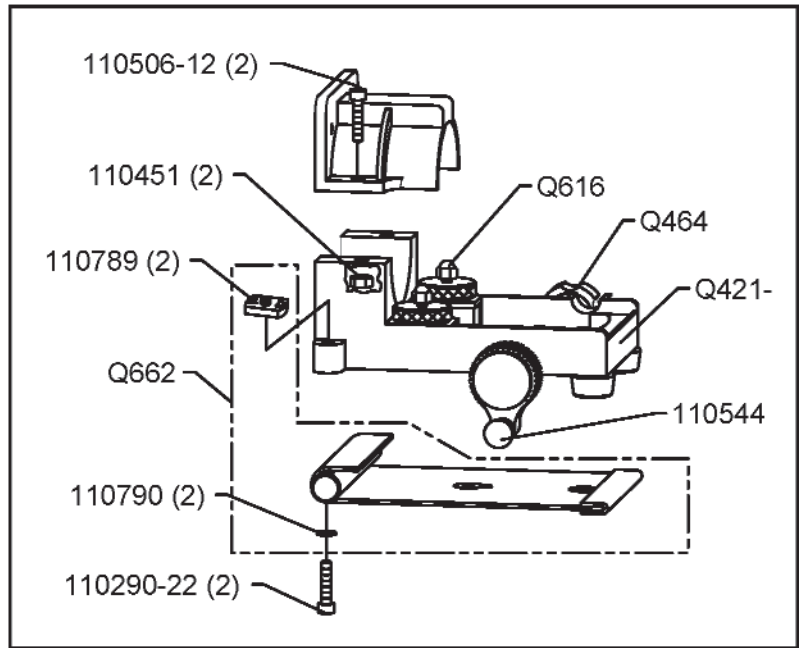

ACCESSORY

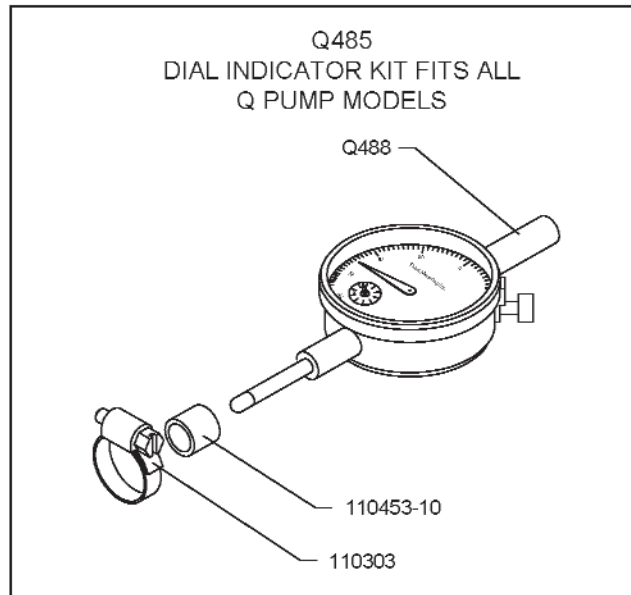

FMI MODEL Q PUMPS PARTS IDENTIFICATION SHEET Q431-05

Q421-5 BASE ASS'Y, QSYX Q421-7

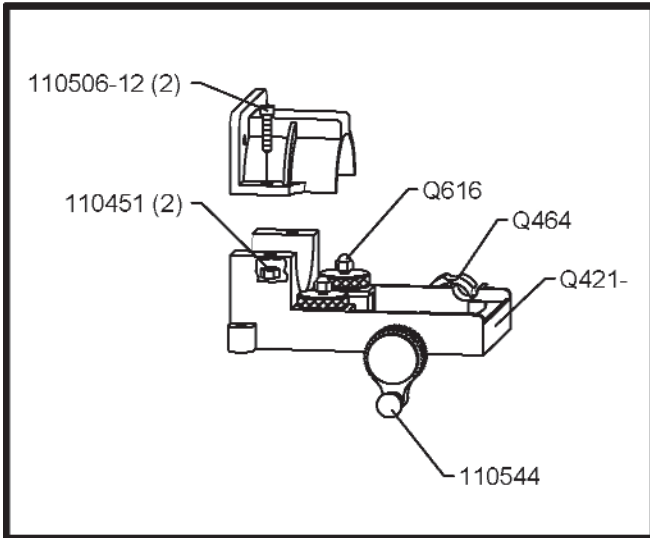

QP PUMP PEDESTAL

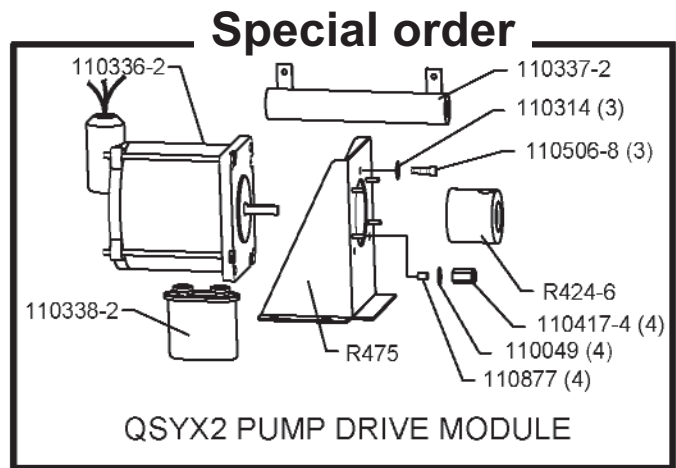
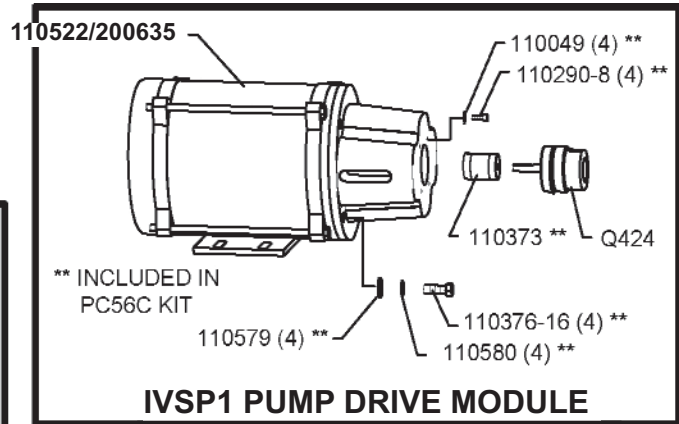
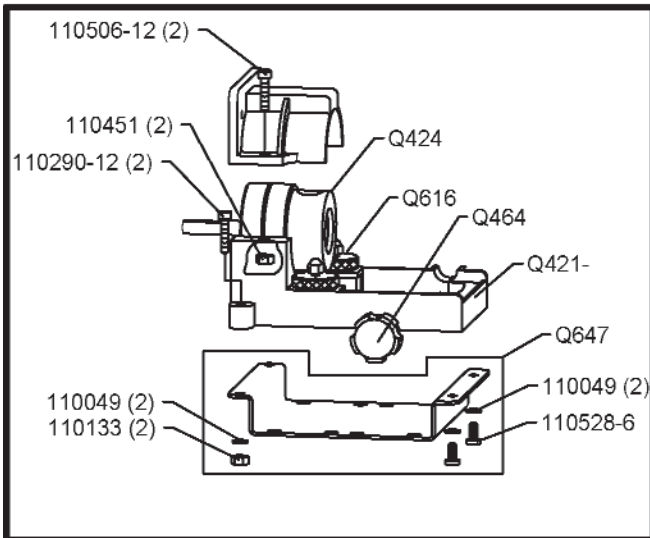

IMPORTANT!

WHEN ORDERING REPLACEMENT PARTS, PLEASE MENTION MODEL & SERIAL NUMBERS OF PUMP ON WHICH THEY WILL BE USED.

FOR ADDITIONAL INFORMATION CALL TOLL FREE 800-223-3388 or 516-922-6050 / FAX 516-624-8261 email: pumps@fmipump.com

V300 STROKE RATE FOR CONTROLLER FOR MODELS QV, Q2V, QVG50, & RHV

General Description

The V300 Stroke Rate Controller provides precision flow control for FMI variable speed "V" Series pumps. The V300 accomplishes this by varying the pump stroke rate from 5% to 100% of the drive's rated speed range of 90 to 1800 Strokes per Minute (SPM) or 5-50 strokes. The complete pump system consists of the V300 Controller and a variable speed "V" Series Pump. The V300 and pump are connected via a single cable (standard length is 4 meters while optional extension cables up to 20 meters are readily available).

The pump is comprised of a 90 volt DC pump drive module (PDM) with integrally mounted pump head module (PHM), and is available in two configurations, QV and RHV, to accommodate FMI's full range of pump head sizes.

V300 Features:

- 3 1/2 Digit LCD displays percent of Flow/Speed.
- Selectable Manual or Analog flow rate control.
- Manual setting of flow rate with 0.1% adjustability

- Analog Input selectable 4-20 mA, 0-5 VDC, and 0-10 VDC input for communication with process instrumentation.
- Start, Stop, and Reverse Flow while maintaining flow settings.
- Current fold back eliminates stalled motor/ electronics damage.
- Universal Power accepts 100-240 VAC 50/60 Hz
- Quick connections for power, analog input, and pump modules.
- Rugged, Anodized Aluminum Enclosure designed for bench-top or wall mounting.

For more information refer to our W300 Instruction manual available at our website at www.fmipump.com under literature.

Speed Linearity

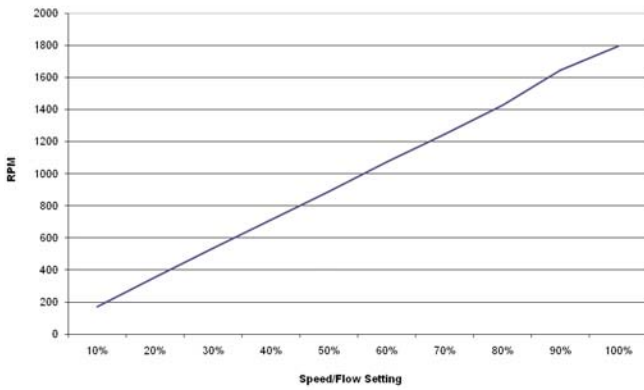

4-20 mA Linearity

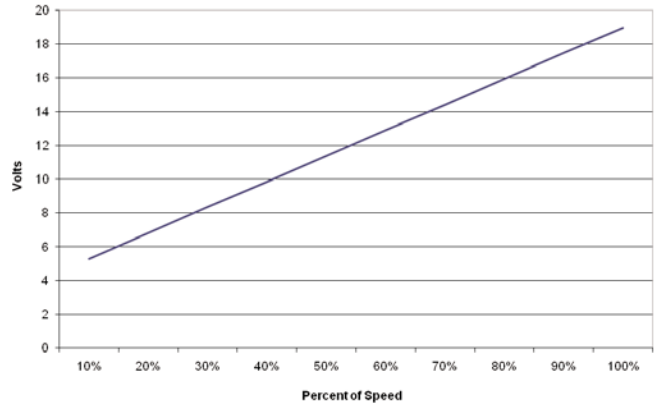

0-10 Volt Linearity

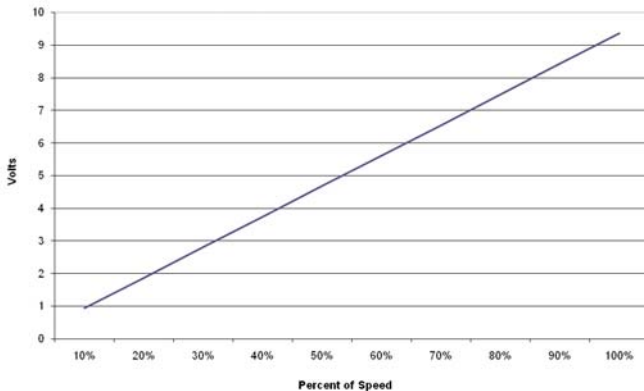

0-5 Volt Linearity

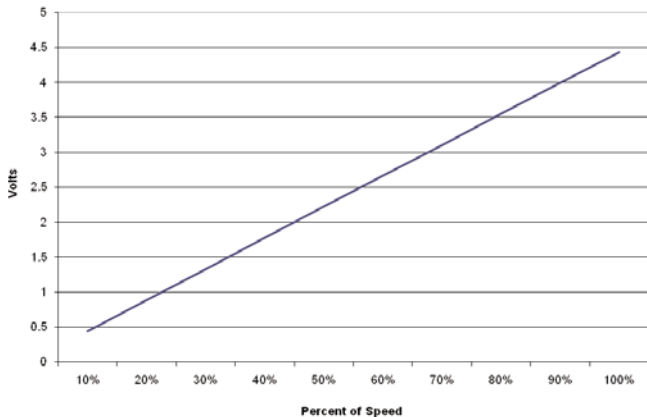

Q PUMP DRIVE MODULE - PARTS PRICE LIST

PART NO.	DESCRIPTION	PART NO.	DESCRIPTION
Q421-1	BASE ASS'Y QP	110290-10	SCREW, SKT HD #8-32 X 5/8"
Q421-3	BASE ASS'Y QB, QD, QV, QBG	110290-22	SCREW, #8-32 X 1 3/8"
Q421-4	BASE ASS'Y QSY	110297-6	DRIVE SCREW , 8-32 X 3/8"
Q421-5	BASE ASS'Y QSYX	110306-1	MOTOR, QSY 115V, 60Hz
Q421-6	BASE ASS'Y QG, QVG50	110306-2	MOTOR, QSY 230V, 50/60Hz
Q421-7	BASE ASS'Y QDX	110314	WASHER, #10 INT. LOCK
Q424	SPINDLE ASSEMBLY QP, QDX	110336-2	MOTOR 230 VAC 50/60Hz QSYX
Q447	BUSHING, FLOW CONTROL	110337-2	RESISTOR (110336-2 230V, 50/60Hz)
Q454-3	FOLLOWER	110338-2	CAPACITOR (110336-2 230V, 50/60Hz)
Q464	STROKE LENGTH ADJUSTMENT KNOB	110355-1	MOTOR, 12 VDC QB
Q485	DIAL INDICATOR KIT	110373	DRIVE COUPLING
Q616	RETAINER ASSEMBLY	110376-16	BOLT, HEX HD 3/8 -16 X 1"
Q647	BASE MOUNTING KIT	110417-4	STANDOFF, HEX 8-32 X 1/4" FEM.
Q662	TILT STAND KIT	110454	CAP NUT 8-32
		110471	LOCK NUT 1/4-20
R424-1	SPINDLE ASSEMBLY QD, QG, QB, QV, QVG	110491	WASHER, FLAT 1/4" STD
R424-6	SPINDLE ASSEMBLY QSY, QSYX	110505	WASHER, SHOULDER, NYLON
R475	FOOT QSYX	110506-8	SCREW, SKT HD CAP 10-32 X 1/2"
P56C	FACE MOTOR ADAPTER KIT	110509	ADAPTER, PC56C
V109	MOTOR ASSEMBLY QV	110522	MOTOR, X-PROOF QDX 115/230 VAC 60 HZ
V109G	MOTOR ASSEMBLY QVG50	110542-6	SCREW, HEX HD NYLON 8-32 X 3/8"
110049	WASHER #8 INT. LOCK	110544	SPEED KNOB
110258	FOOT, RUBBER	110579	WASHER, FLAT 3/8"
110262	MOTOR, QD PUMP 115V, 60Hz	110580	WASHER, LOCK INT. 3/8"
110262-2	MOTOR, QD PUMP 230V , 50/60 Hz	110608	SPRING AND BRUSH SET, QVG50
110286-6A	MOTOR, QG 6 RPM 115V, 60Hz	110609	BRUSH CAP , QVG50
110286-20A	MOTOR, QG 20 RPM 115V, 60 Hz	110671-4	SCREW, SET 8-32 X 1/4"
110286-50A	MOTOR, QG 50 RPM 115V, 60 Hz	110837-01	SPRING BRUSH SET 12 VDC - GRAY MOTOR
110286-150A	MOTOR, QG 150 RPM 115V, 60 Hz	110838-01	SPRING BRUSH SET 90 VDC - GRAY MOTOR
110286-400A	MOTOR, QG 400 RPM 115V, 60 Hz	110839-01	BRUSH CAP 12, 90 VDC - GRAY MOTOR
110290-8	SCREW, SKT HD 8-32 X 1/2"	110877	SPACER
		200635	Motor + Cable ASS'Y, 1/2HP,230 VAC

*Please
call for Pricing*

PUMP DRIVE REPAIR SERVICE

Should your FMI PUMP DRIVE or SUBASSEMBLY need repairs, you should first contact the Customer Service Department for a RETURN AUTHORIZATION NUMBER; you may then ship it to us post-paid. You will be charged a flat service fee for each Pump Drive Module or subassembly returned plus the cost of parts used and the postage required to return it to you.

After examining a returned pump or subassembly by FMI Service Department, you will be requested to approve the charges before repair work is started.

PARTS ORDERS

MINIMUM ORDER APPLIES FOR DOMESTIC or FOREIGN (Invoice price exclusive of shipping)

SHIPPING

Parts and repair orders will be shipped via United Parcel Service or U.S. Postal Service unless other means are specified.

ALL PRICES ARE QUOTED IN U.S. DOLLARS, FOB SYOSSET, NY - Subject to change without notice.

For Additional Information Call - Toll Free 800-223-3388 or email us at: pumps@fmipump.com

Continued from page 3

- j) Place head seal components R413 and R489 into the head end of CYLINDER CASE R405-SAN, apply CYLINDER NUT R406-S.
- k) Wrench tighten each PORT NUT 110348-P 1/6 turn.
- l) Wrench tighten each CYLINDER NUT R406-S 1/2 turn, piston end first.
- 18. PISTON SEAL REPLACEMENT** (please see para 5.) When R408 SEALS are replaced, the following procedure should be followed: (please see figs. 3,4)
 - a) Place GLAND NUT R406 and GLAND WASHER R409 on PISTON ASSEMBLY R423.
 - b) Place the lip seal installation tool over the end of the piston. Slide the tool until piston is seated in tool. (See lip seal insertion tool table below).
 - c) First "Form" lip of lip seal by gently placing a

- lip seal R408 on tool, lip side last. Carefully rotate the seal on the tool while sliding the seal over the tool's neck to avoid damage to the lip. Then remove seal and reverse lip direction (FIG.3)
- d) Gently place one "formed" LIP SEAL R408 on piston, **lip side first**, carefully rotating the seal on the tool until it is past the tool and on the piston
- e) Gently place one LIP SEAL R408 on piston, **lip side last**. Carefully rotate the seal on the tool to avoid damage to the lip while passing over the tool to the piston (fig. 4).
- f) Remove installation tool from the piston.
- g) Insert piston into cylinder approximately one inch.
- h) Apply GLAND NUT R406 to cylinder threads, seat gland nut, then tighten to 1/3 turn maximum.
- 19. PISTON SEAL SETTING.** After installing

- new lip seals (part R408) in pump head it is recommended that the seals be set (formed in place) by fluid pressures generated by pump action. To accomplish this:
 - a) Operate the pump spindle clockwise for 10 or 20 strokes at maximum setting, handling water (left to right mode facing pump head) with suction line blocked or pinched off. This will create a vacuum in the pump head, permitting atmospheric pressure to shape the outer seal member tightly around the piston.
 - b) Reverse the pumping direction (pump head angle reversal) and intermittently block the line leading from the left hand port. This will generate pressure in the seal area of the pump head, causing the inner seals to form intimately around the piston.

Lip Seal Insertion Tools, Q431-05

Piston Size Code	Piston Diameter (inches)	Tool Part Number
Q0	1 / 8	500074
Q1	1 / 4	500071
Q2	3 / 8	500080
Q3	1 / 2	500081

WHEN ORDERING REPLACEMENT PARTS PLEASE MENTION MODEL AND SERIAL NUMBERS OF THE PUMP ON WHICH THEY WILL BE USED.

Record your Model and Serial Numbers below. This will be useful when ordering replacement parts.

PUMP HEAD MODULES (PHM)		PUMP DRIVE MODULE (PDM)	
PHM MODEL NUMBER	PHM SERIAL NUMBER	PDM MODEL NUMBER	PDM SERIAL NUMBER
_____	QB _____	_____	QA _____
_____	_____	_____	_____
_____	_____	_____	_____

PLEASE NOTE:

Pistons and cylinders are dimensionally mated. For most satisfactory performance, they should be ordered as mated sets.



FLUID METERING, INC.
 5 AERIAL WAY, SUITE 500, SYOSSET, NY 11791
 (800) 223-3388 (516) 922-6050 Fax: (516) 624-8261 <http://www.fmipump.com>

