

High Output Vacuum/Pressure Pump

User Guide

Catalogue Numbers:

WP62 115 60 (115 V, 60 Hz)

WP62 220 50 (230 V, 50 Hz, 1.1 A)

WP62 100 60 (100 V, 50/60 Hz)

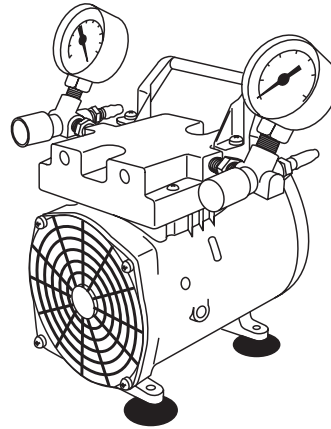

Notice

The information in this document is subject to change without notice and should not be construed as a commitment by Millipore Corporation or an affiliated corporation. Neither Millipore Corporation nor any of its affiliated corporations assumes responsibility for any errors that may appear in this document. This manual is believed to be complete and accurate at the time of publication. In no event shall Millipore Corporation or any of its affiliated corporations be liable for incidental or consequential damages in connection with or arising from the use of this manual.

© 2009 Millipore Corporation. All rights reserved.

Millipore and Millex are registered trademarks of Millipore Corporation.
The M mark is a trademark of Millipore Corporation.



P36512, Rev. E, 05/09

Introduction

The Millipore high output vacuum/pressure pump is a continuously-running constant air-flow type unit for use with laboratory equipment. This vacuum/pressure pump combines the quietness and durability of a diaphragm pump with the performance of a piston-type pump. It compresses air by means of a motor-driven piston. This pump is intended for filtration of liquids or for other continuous or intermittent uses, with all types of filter holders, multi-well devices, manifolds, and other laboratory equipment.

CAUTION: Always use the supplied hydrophobic vent filter or a vacuum-flask water trap in conjunction with the pump, as indicated in Figures 1 and 2. Never pump or draw liquids through the pump, as this will damage the pump.

The pump has these features:

- The motor and pump are permanently lubricated.
- A thermal overload switch with automatic reset protects the motor.
- Low operating noise is further minimized by rubber feet.
- A Millex®-FA₅₀ hydrophobic vent filter and 27 in. (69 cm) of 1/4 in. (6 mm) I.D. vacuum tubing are supplied with the pump.

Rules for Safe Operation



The motor is thermally protected and will automatically restart unexpectedly when the overload device resets. Do NOT pump flammable or explosive gases or vapors or operate this pump in an atmosphere containing flammable or explosive gases or vapors.

Use of this pump in a manner not specifically stated in this user guide may result in severe bodily injury.

Read and understand the information in this owner's manual before operating the vacuum/pressure pump.

- The vacuum/pressure pump should be operated in a dry, clean, and well ventilated area.
- When the unit is not in use, wrap the power cord around the vacuum/pressure pump and store in a dry place. Do not abuse the cord.
- Replace the Millex-FA₅₀ vent filter (SLFA 050 10) if necessary.
- Inspect hose, plug, and cord for signs of damage before use. Do not use if a deficiency is found. Never operate a damaged unit. Contact Millipore for replacement parts; see Technical Assistance section for details.
- This vacuum/pressure pump needs no lubrication. Applying oil to any part may result in polluted air delivery to the air-handling equipment and will damage the pump.
- To operate at maximum efficiency, the pump system must be thoroughly clean. Refer to the Maintenance section for details on properly cleaning the pump.
- Compressed air blast must never be aimed at anyone because it can cause serious injury. Keep children away.
- All vacuum/pressure pumps generate heat, even under normal operating conditions. To avoid serious burns, never touch the head parts or tubing during and immediately after operation.
- When filtering acids, bases, or organic vapors or gases, use the Millipore Chemical Duty Vacuum/Pressure Pump (WP61 115 60, WP61 220 50, WP61 100 60).

Usage Guidelines

- Always use the Millex-FA₅₀ vent filter and 1/4 inch silicone tubing included with the pump when applying vacuum. This will prevent liquids or vapors from entering the pump. A properly attached Millex-FA₅₀ vent filter is illustrated in Figure 1.
- For maximum protection of the pump, use the Millex-FA₅₀ vent filter AND a vacuum trap to protect the pump from vapors and gases. The vacuum trap consists of a 1 liter filtering flask (Millipore cat. no. XX10 047 05), No. 8 stopper (XX10 047 08) and silicone tubing. Additional tubing is available as Millipore cat. no. XX71 000 04. This assembly is illustrated in Figure 2.
- Never pump or draw liquids through the pump. This will damage the pump. The filter flask and vacuum trap should be emptied after each use.

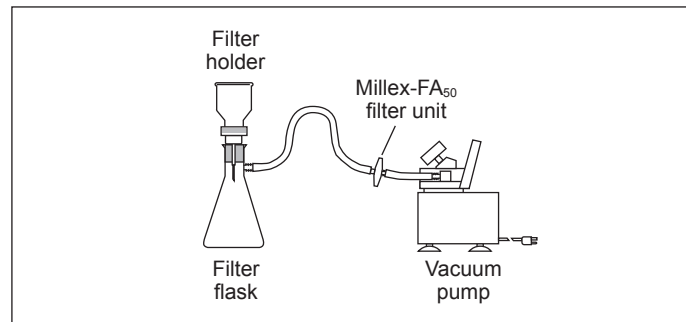

Figure 1. Proper use of Millex-FA₅₀ filter

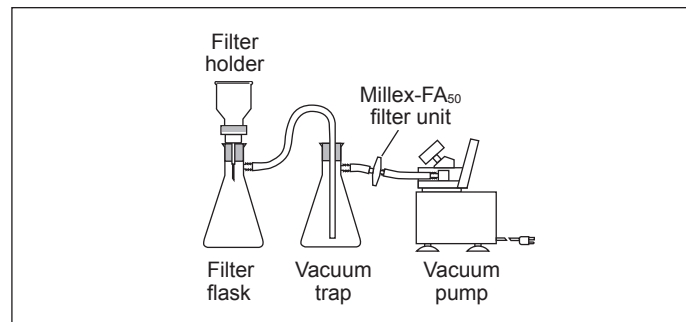
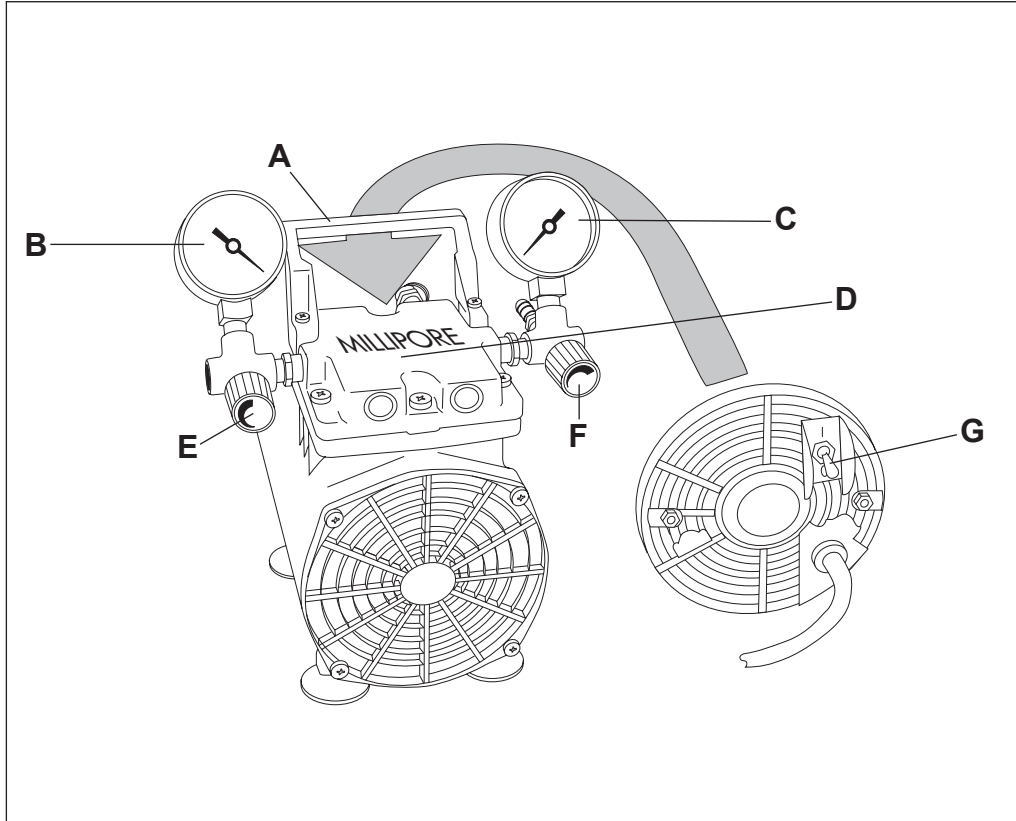

Figure 2. Proper use of vacuum trap and Millex-FA₅₀ filter

Pump Components



Letter Description

A	Handle
B	Vacuum gauge
C	Pressure gauge
D	Pump head
E	Vacuum valve
F	Pressure valve
G	On/off switch

Identification Symbols

WARNING



ON (Power)



OFF (Power)



Direction of Pressure Control (Valves)



How to Use the High Output Vacuum/Pressure Pump

The Millipore Vacuum/Pressure Pump is shipped ready for use. See the Specifications section for required operating conditions.

CAUTION: The pump is rated for indoor use only.

CAUTION: Be sure available power matches unit requirements. A grounded three-conductor AC electrical source is required. Units are available for 115 VAC 60 Hz, 100 VAC 50/60 Hz, or 230 VAC 50 Hz. See the Specifications section for details of electrical supply options available.

1. Unpack the unit and retain all packing material until you verify proper product operation.
2. The unit rests on four vibration isolator pads. Place the unit on a suitable surface, such as a bench, desk, or table. Be sure not to block the ventilation holes located on the motor housing.
3. Select appropriately-sized tubing, according to your application. Use approximately 1/4 in. I.D. tubing to withstand the anticipated pressure or vacuum.
CAUTION: During vacuum filtration, use the supplied Millex-FA₅₀ hydrophobic vent filter, to prevent excessive amounts of liquids or mist from entering the pump (figure 1). For maximum protection, use a vacuum-flask water trap (figure 2).
4. Prepare the necessary equipment or filter holder and connect the tubing to the equipment. Do not connect the tubing to the pump.

5. Plug the power cord into an appropriate electrical source.

CAUTION: Do not turn the pump on with equipment or filter holder already attached.

If the pump is inadvertently turned on with the tubing fully connected and it does not run, turn off the pump and disconnect the tubing. Restart the pump and then reconnect the tubing. If the pump's thermal overload switch automatically shuts off the motor, disconnect the tubing and allow the pump to cool for at least 10 minutes before restarting. Reconnect the tubing only after the pump is operating.

6. Turn on the pump, using the toggle switch located at the rear of the pump.
7. Connect the tubing from the filter holder or other equipment to the pump and begin your procedure.
8. **If using the pump for vacuum:** Adjust the vacuum by closing the pressure regulator and opening the vacuum regulator fully (counter-clockwise). Slowly tighten down (clockwise) the vacuum regulator until you obtain the desired vacuum reading on the vacuum gauge.
If using the pump for pressure: Adjust the pressure by turning the vacuum regulator down fully and opening the pressure fully (counter-clockwise). Slowly tighten down (clockwise) the pressure regulator until you obtain the desired pressure reading on the pressure gauge.
9. Turn off the pump when you are finished. Disconnect the tubing first from the pump and then from the filter holder or other equipment.

Maintenance

Under normal operating conditions, and using proper handling procedures, the high-output vacuum/pressure pump should provide many hours of trouble-free operation.

Millipore dry vacuum/pressure pumps are 100% oil-free. The pump employs a non-lube piston and cylinder. No maintenance is necessary for the bearings. All bearings are sealed and permanently lubricated. Lubrication should not be attempted. The units are built for continuous duty operation with quietness and durability.

CAUTION: Do not lubricate any of the parts with oil, grease, or petroleum products. Do not clean with acids, caustics, or chlorinated solvents. Do not replace the connecting rod or motor bearings.

Troubleshooting

Vacuum Problems

Leakage, contamination, and unusual out-gassing are the general causes of problems associated with poor vacuum. To operate at maximum efficiency, a system must be thoroughly clean. If the system is completely clean and free from leaks, and unwarranted vacuum problems still exist, the pump should be checked. A simple criterion for the condition of the pump is the determination of its maximum vacuum capability. This can be accomplished by blocking the intake and reading the vacuum level on the gauge.

Pressure Problems

Leakage and contamination are the general causes of problems associated with poor pressure. To operate at maximum efficiency, a system must be thoroughly clean. If the system is completely clean and free from leaks, and unwarranted pressure problems still exist, the pump/compressor should be checked by a service technician.

Troubleshooting Guide

Poor Pumping Speed	Poor Pressure	Loud Unit	Possible Cause	Corrective Action
■	■	■	Damaged valves	Replace flapper valves
■	■	■	Debris in valves	Remove debris and check for valve damage
■	■	■	Damaged O-rings	Replace O-rings
■	■	■	Loose head screws	Tighten head screws
■	■		Loose fittings	Tighten fittings

Repair

Three replacement part kits are available for the high output vacuum/pressure pump. The accompanying drawing outlines the contents of each of the kits. For further information or for help ordering the correct kit, please contact Millipore Technical Service.

Key	Description	Maintenance Kit	Rebuild Kit	Rebuild Kit
		WP62 MNT 00	(115 V) WP62 RBD NA	(230 V/100 V) WP62 RBD EU
1	Handle screws	2	2	2
2	Head screws	4	4	4
3	Head O-ring	1	1	1
4	Pressure regulator assembly	—	—	—
5	Pressure gauge	—	1	1
6	Vacuum regulator assembly	—	—	—
7	Vacuum gauge	—	1	1
8	Valve plate assembly (includes flapper [leaf] valves)	—	1	1
9	Cylinder O-ring	1	1	1
10	Connecting rod assembly*	—	1	1
11	Rubber suction feet	—	—	—

*The connecting rod assembly shipped with the rebuild kit for the 115 V pump is different from the one shipped with the rebuild kit for the 230 V and 100 V pumps.

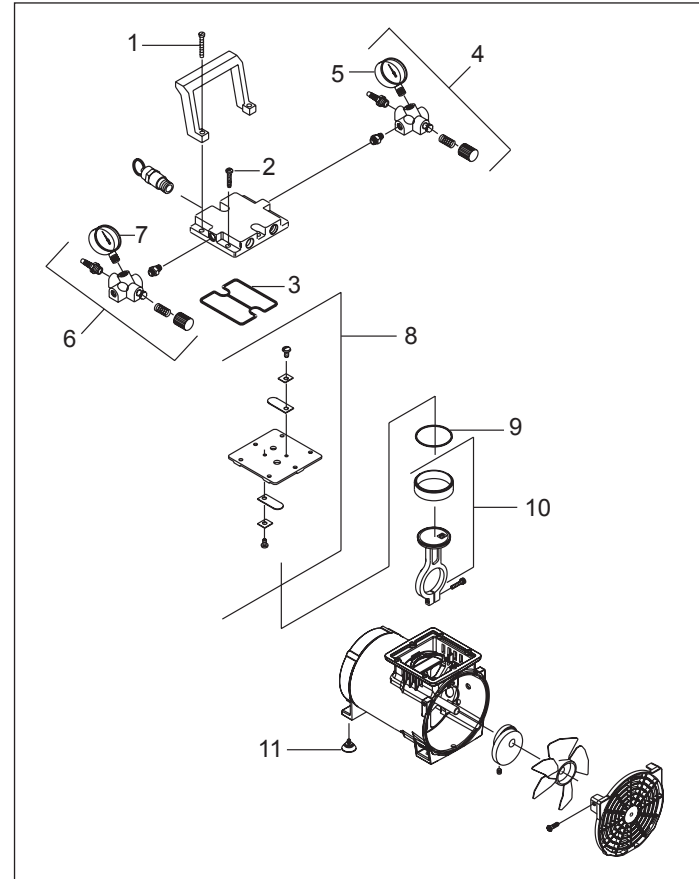

Specifications

Performance

Vacuum	27.2 inches of Hg
Pressure	50 psi continuous, 80 psi intermittent
Regulatory Compliance	115 V UL/CSA recognized; 230 V CE compliant 2004/108/EC 2006/95/EC 98/37/EC
Sound Level	Less than 60 dB(A)

Dimensions

	WP62 220 50, WP62 115 60	WP62 100 60
Length	8.0 in. (20.3 cm)	7.3 in. (18.5 cm)
Width	9.0 in. (22.9 cm)	9.0 in. (22.9 cm)
Height	9.8 in. (24.9 cm)	10.2 in. (25.9 cm)
Weight (approximate)	11 lbs (5 kg)	14.5 lbs (6.6 kg)
Tubing Connectors	Stepped 1/4 in. hose barb	

Materials of Construction

Body and pump head	Die cast aluminum
Pump Type	Piston with PTFE seal
Leaf valves	High grade stainless steel

Electrical Specifications

115 V, 60 Hz <i>or</i> 100 V, 50/60 Hz	AC shaded-pole, single phase, 1/7 HP motor 3-pronged, grounded cord and plug
230 V, 50 Hz AC	Permanent split capacitor, 1/3 HP motor HAR cordage, CEE 7/7 (Schuko)
Line voltage limits	±10% of supply voltage

Environmental Conditions

Temperature	5 °C (41 °F) to 40 °C (104 °F)
Relative Humidity, Max.	80% for temperatures up to 31 °C, decreasing to 50% at 40 °C
Altitude, Max.	2000 meters
Pollution Degree	2, per IEC 664 (indoor usage: lab, office, etc.)
Installation Category	II, per IEC 624 (local level: appliances, portable equipment, etc.)

Air Flow Rates

Air flow rates at different vacuum and pressure settings are shown in the next section. For vacuum operation, pump exit pressure is one atmosphere (14.7 psia). To obtain indicated performance, specified operating conditions must be met.

Vacuum	Flow Rate		Pressure		Flow Rate		
	mbar	in. Hg	L/min	CFM	bar	PSIG	L/min
1013	0	34	1.2	0	0	34	1.2
840	5	27	0.96	0.5	7.5	34	1.2
670	10	21	0.73	1.0	15	28	1.0
510	15	14	0.48	2.0	29	25	0.9
340	20	7.6	0.27	3.0	44	24	0.83
170	25	2	0.07	5.0	73	17	0.59
98	27.2	0	0	7.0	102	12	0.42

Product Ordering Information

This section lists the catalogue numbers for the High Output Vacuum/Pressure Pump. See the Technical Assistance section for information about contacting Millipore. You can also buy Millipore products on-line at www.millipore.com.

Description	Catalogue Number
High Output Vacuum/Pressure Pump	
115 V, 60 Hz	WP62 115 60
230 V, 50 Hz	WP62 220 50
100 V, 50/60 Hz	WP62 100 60
Replacement Parts	
Pump Maintenance Kit includes head O-ring, cylinder O-ring, handle screws, and head screws	WP62 MNT 00
Pump Rebuild Kit includes pressure gauge, vacuum gauge, valve plate assembly including flapper valves, head O-ring, cylinder O-ring, connecting rod assembly, handle screws, and head screws	WP62 RBD NA (115V) WP62 RBD EU (100V & 230V)
Milllex-FA ₅₀ filter unit, 10/pk	SLFA 050 10
Pressure tubing, silicone, 25 ft	XX80 000 25
Vacuum tubing, silicone, 4 ft	XX71 000 04

Technical Assistance

For more information, contact the Millipore office nearest you. In the U.S., call **1-800-MILLIPORE** (1-800-645-5476). Outside the U.S., see your Millipore catalogue for the phone number of the office nearest you or go to our web site at www.millipore.com/offices for up-to-date worldwide contact information. You can also visit the tech service page on our web site at www.millipore.com/techservice.

Declaration of Conformity

Model WP62 220 50 is in conformity with the following directives:

Electromagnetic Compatibility (EMC) Directive 2004/108/EC
Low Voltage Directive 2006/95/EC
Machinery Directive 98/37/EC

Warranty

The applicable Millipore Warranty and limited liability for products listed in this publication may be found at www.millipore.com (search on "Terms and Conditions of Sale").



642559